

serie/range
FMRe



Morella Forni®

Forno rotante a legna + piano riscaldato elettrico
Rotary wood oven + electric heated bedplate



- I forni FMRe hanno un funzionamento principalmente a legna, con sistema ausiliario di riscaldamento elettrico della platea rotante.

- Gli FMRe appartengono alla famiglia dei forni rotanti, dove la platea, motorizzata a velocità e direzione variabili, dona uniformità e diminuzione dei tempi di cottura.

- Gli elementi riscaldanti sotto la platea rotante conferiscono stabilità termica alla base del forno, per rendere più veloce ed omogeneo il processo di cottura.

- La zona di combustione legna è separata dalla platea rotante tramite una protezione metallica
- Il cassetto di caduta e raccolta cenere agevola le operazioni di pulizia, migliora la combustione della legna e le condizioni igieniche di cottura.
- Riscaldamento indipendente della platea con gestione e controllo termostatico della temperatura
- Una grande massa refrattaria e la coibentazione sono progettate per elevare il rendimento, e diminuire i costi di esercizio e le perdite di calore.
- Il calore sviluppato per il riscaldamento della platea viene veicolato nuovamente all'interno della cupola sfruttandolo nuovamente economizzando i consumi del forno.
- grazie al sistema di controllo la potenza elettrica viene autoregolata in gestione automatica diminuendo e aumentando di intensità in base alla temperatura impostata, economizzando i consumi e semplificando l'uso.
- Sistema brevettato di auto pulizia dei sedimenti intorno alla platea rotante.



- FMRes are mainly wood ovens, with an auxiliary electric system heating their revolving bedplate.

- FMRes are part of rotating oven's family, their motorized bedplate with variable speed and direction results in quicker and homogeneous baking.

- Bedplate heating elements allow better thermal stability to the baking base, for quicker and more homogeneous baking results.

- A metal guard separates wood burning area from revolving bedplate.

- An external metal drawer collects ashes and debris falling from cooking chamber grooves, to help keeping the baking area clean, improving wood combustion and overall hygiene.

- Independent bedplate heating, with temperature-based control system.

- The huge refractory mass and extra careful thermal insulation increase oven's efficiency, lower operating costs and heat loss.

- Bedplate heat is redirected into cooking chamber to increase efficiency and lower consumption.

- In auto mode: heating control system manages electric power, raising or lowering heat intensity according to set temperature, to enhance energy saving and ease of use.

- Patented automatic debris cleaning system around the revolving bedplate.



FORNO ROTANTE/ROTARY OVEN

le finiture della linea/range finishes • **FMRe**

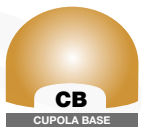

Mod./Ref.	Capacità pizze Ø 30 cm./Capacity pizzas Ø 30 cm.	Produzione oraria/Productivity per hour
FMRe100	4	70 pizze/h
FMRe110	5	90 pizze/h
FMRe130	8	120 pizze/h
FMRe150	10	160 pizze/h

Tabella forni legna serie "FMRe" norma DIN 18 880/ Wood table ovens series "FMRe" norm DIN 18 880

Ref./Mod.	FMRe100	FMRe110	FMRe130	FMRe150
Potenzialità elettrica (kW) / Electric heat output (kW)	7,5	7,5	8,5	9,5
Potenzialità legna (kW) / Wood heat output (kW)	25	28	35	46
Aria di combustione (m3/h) / Combustion air (m3/h)	165	167	173	180
Temperatura fumi scarico (°C) / Exhaust fumes temperature (°C)	85	100	110	120

certificazioni
certifications

costruiti ed omologati
secondo le norme
manufactured and certified
according to norms



• Misure in cm ±2% • Le caratteristiche e i dati riportati nel presente catalogo possono subire variazioni senza preavviso / • Sizes in centimeters ±2% • Data and features in this catalog may change without notice

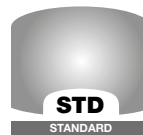
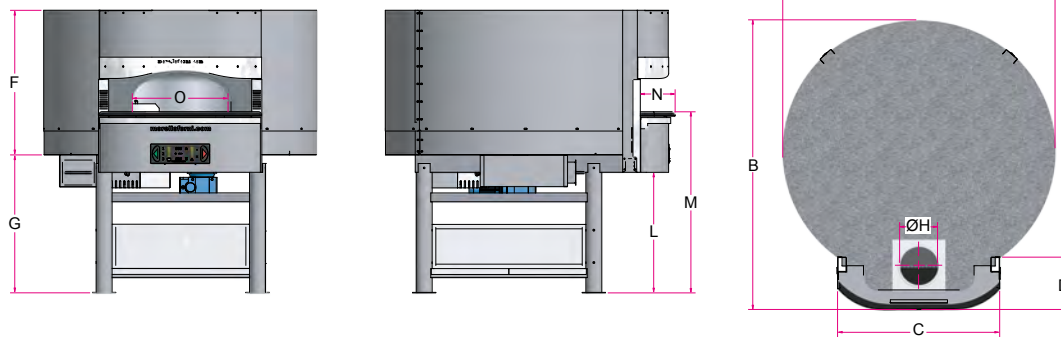

serie
range

FMRe

**Forno rotante a legna +
piano riscaldato elettrico**
*Rotary wood oven +
electric heated bedplate*

Mod./Ref.	ØH	A	B	C	D	F	G	L	M	N	O	peso/weight (kg)
FMRe100	25	166	177	102	30	100	94	82	122	25	55	1900
FMRe110	25	186	196	112	30	100	94	82	122	25	65	2300
FMRe130	25	212	212	122	30	100	94	82	122	25	75	2700
FMRe150	25	230	245	122	30	126	94	90	124	25	82	3900

**FORNO ROTANTE/
ROTARY OVEN**

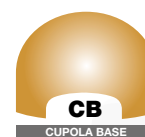
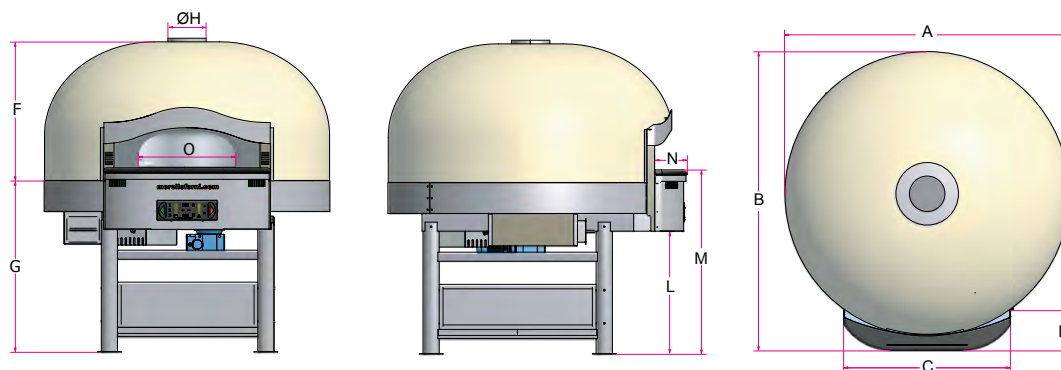

Mod./Ref.	ØH	A	B	C	D	F	G	L	M	N	O	peso/weight (kg)
FMRe100	25	166	177	102	30	112	94	82	122	25	55	2000
FMRe110	25	190	200	112	30	112	94	82	122	25	65	2400
FMRe130	25	212	212	122	30	112	94	82	122	25	75	2800
FMRe150	25	230	245	122	30	140	94	85	124	25	82	4000

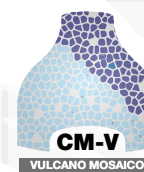
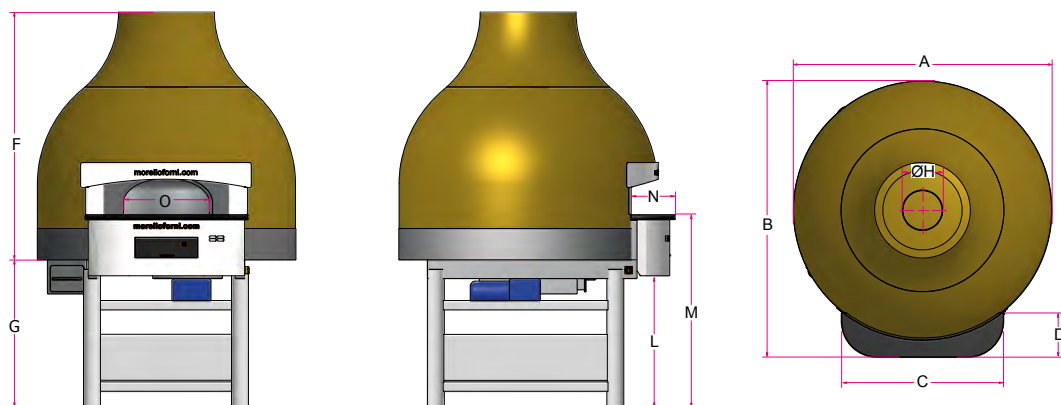

Mod./Ref.	ØH	A	B	C	D	F	G	L	M	N	O	peso/weight (kg)
FMRe100	25	166	177	102	30	132	94	82	122	25	55	2100
FMRe110	25	190	200	112	30	132	94	82	122	25	65	2500
FMRe130	25	212	212	122	30	132	94	82	122	25	75	2900
FMRe150	25	230	245	122	30	160	94	85	124	25	82	4100

alcune nostre finiture
some of our
finishes



MORELLO FORMI s.a.s.
Via B. Parodi, 35 - 16014 Ceranesi (Genova) - Italy
Tel. +39 010 7401194 • Fax +39 010 7492194
email: info@morelloformi.com